



RFS CompactLine® and CompactLine® Easy Antennas are designed for short-haul microwave systems in all common frequency ranges from 6 GHz to 86 GHz. They are typically deployed in dense urban areas, metropolitan and suburban locations, aggregation points. They are especially optimized to integrated radios to reduce costs, installation complexity and time.

FEATURES / BENEFITS

- Sizes ranging from 0.3 m (1 ft) to 1.8 m (6 ft)
- Frequencies ranging from 5.925 GHz to 86 GHz with support for four wideband frequency ranges (5.925-7.125, 7.125-8.5, 10.0-11.7, and 71.0-86.0 GHz) to reduce antenna requirements and simplify logistics
- Single (SB and SC) and dual-polarized (SBX and SCX) models with the ability to upgrade from single to dual polarization and change frequencies in the field
- Low-profile design to reduce transportation requirements, wind load and antenna weight
- Simplified mounting design to accelerate installation
- CompactLine EASY models are extra light and easy to transport, deploy and upgrade
- Hardcover radomes
- Tested and validated ultra-high (ETSI EN 302 217-4-2 Class 3, FCC Class A) electrical performance
- Support for winds up to 250 km/h (155 mph) and even 320 km/h (195 mph) for SB1/SBX1
- An optional sway bar for antennas 3 ft and larger is available



Technical features

GENERAL SPECIFICATIONS

Product Type		Point to point antennas
Profile		CompactLineEasy
Performance		Ultra High
Polarization		Single or Dual
Antenna Input		Aviat Networks, WTM4000 and ODU600 V2
Reflector		1-part
Radome		rigid
Antenna color		White RAL 9010
Swaybar		

ELECTRICAL SPECIFICATIONS

Frequency	GHz	14.2 - 15.35
3dB beamwidth, (degrees)	degrees	1.5
Low Band Gain	dBi	40.6
Mid Band Gain	dBi	41
High Band Gain	dBi	41.3
F/B Ratio	dB	69
XPD	dB	30
Max VSWR / R L, dB	VSWR / dB	1.38 (16) @ - GHz
Regulatory Compliance		ETSI EN 302217 Range 2 Class 3 Brazil Anatel Class 2 Canada SRSP 314.5 Part C



MECHANICAL SPECIFICATIONS

Diameter	ft (m)	3 (0.9)
Elevation Adjustment	degrees	± 15
Azimuth Adjustment	degrees	± 15
Polarization Adjustment	degrees	Single or Dual
Mounting Pipe Diameter minimum	mm (in)	89 (3.5)
Mounting Pipe Diameter maximum	mm (in)	114 (4.5)
Approximate Weight	kg (lb)	18 (40)
Survival Windspeed	km/h (mph)	252 (155)
Operational Windspeed	km/h (mph)	180 (112)

STRUCTURE

Radome Material		rigid
-----------------	--	-------

FURTHER ACCESSORIES

optional Swaybar		1: SMA-SK-3 (1.35 m x Ø33 mm)
Further Accessories		SMA-SKO-UNIVERSAL : Universal sway bar fixation kit

MOUNTOUTLINE

Dimension_A	mm (in)	999 (39.33)
Dimension_B	mm (in)	375 (15)
Dimension_C	mm (in)	56 (2.2)
Dim_D-89mm(3.5_in)Pipe	mm (in)	379.5 (14.9)
Dim_D-114mm(4.5_in)Pipe	mm (in)	392 (15.5)
Dimension_E	mm (in)	79 (3)
Dimension_F	mm (in)	182 (7)

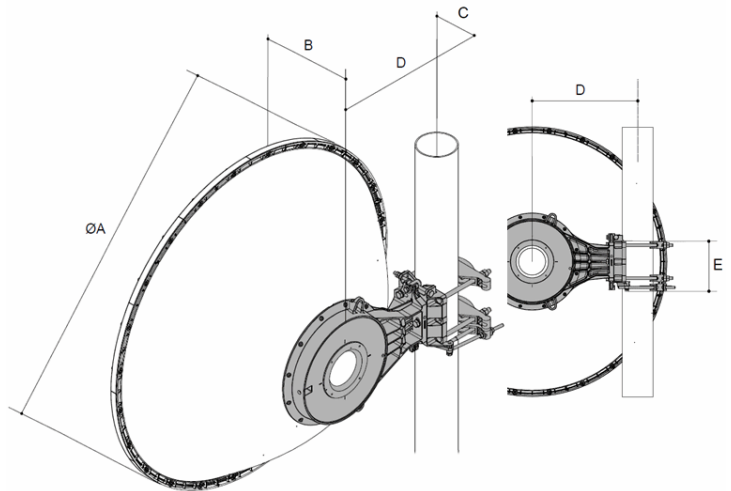

WINDLOAD

Fs Side force max. @ survival wind speed	N (lb)	1451 (326)
Fa Axial force max. @ survival wind speed	N (lb)	2930 (659)
M Torque maximum @ survival wind speed Nm (ft lb)	Nm (lb ft)	1213 (895)

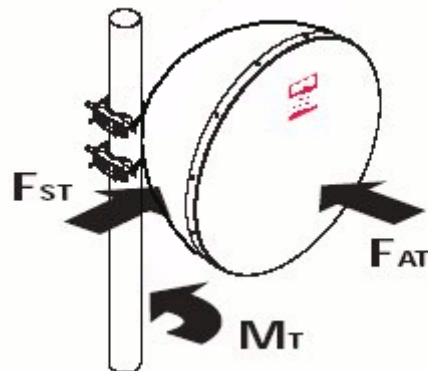



External Document Links

- [Reflector installation](#)
- [Feed installation](#)
- [Mount installation](#)
- [RPE \(I-Q Link Format\)](#)
- [RPE \(PDF format\)](#)
- [RPE \(Pathloss format\)](#)

Notes

This is a model with two RF interface modules in the configuration, one has rectangular output, the other has circular output.